



REF : 398

**CLAPET A BOULE - RACCORDEMENTS TARAUDÉS
BALL CHECK VALVE - THREADED ENDS**

Raccordement taraudé FF BSP

Pression : PN 10 bar

Température : -10°C / +80°C

Traçabilité avec lot de fabrication sur plaquette signalétique

BSP FF threads

Pressure : PN 10 bar

Temperature : -10°C / +80°C

Traceability with batch number

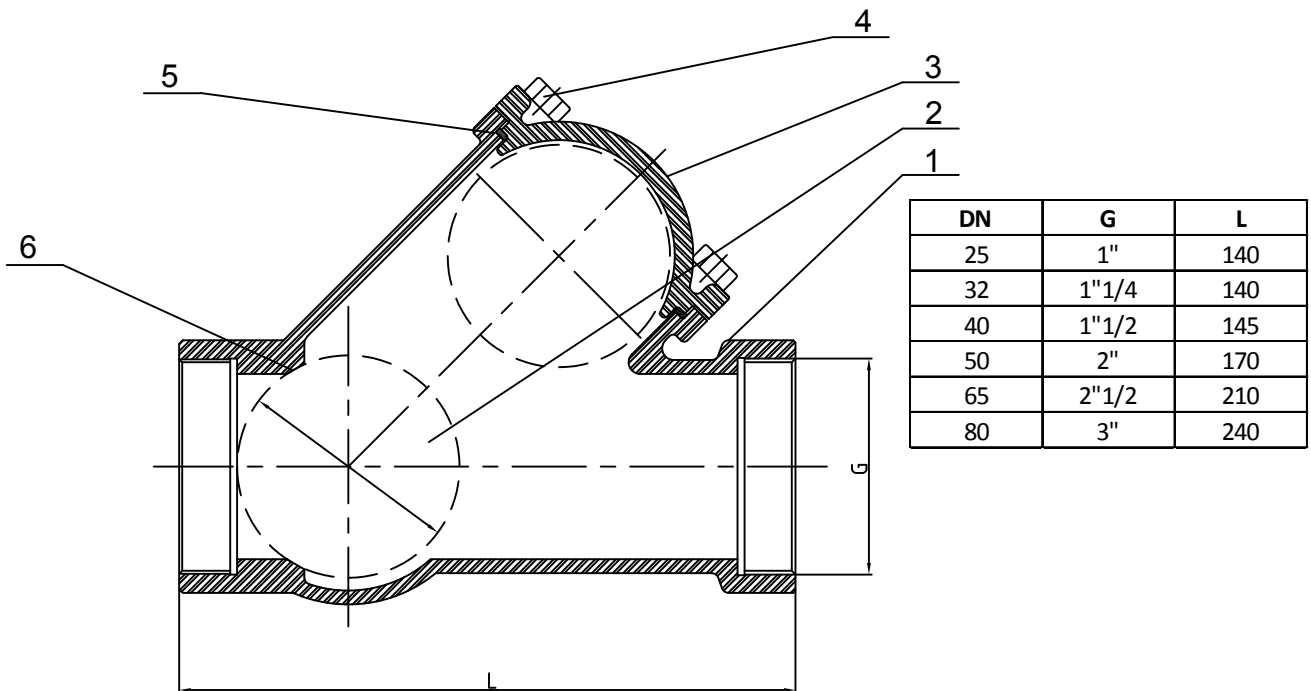

Item	Désignation/Description	Matière / Material	
		DN25-32-40	DN50-65-80
1	Corps / Body	Fonte ductile + epoxy / Ductile iron + epoxy	
2	Chapeau / Cap	Fonte ductile + epoxy / Ductile iron + epoxy	
3	Boule / Ball	Résine / Resin	Aluminium + NBR / Aluminum + NBR
4	Boulons / Bolts	Inox 304 / Stainless steel 304	
5	Joint plat / Flat gasket	NBR	
6	Siège / Seat	NBR	/